



Model BSW-SS

FOOD WARMERS {MERCHANTISERS} BUTTER SERVER, SUPREME™

Date:

Project:

Quantity:

Item Number:



BSW-SS 86540



US LISTED

ALSO AVAILABLE FOR EXPORT

Two Year Warranty

Server Products equipment is backed by a two-year limited warranty against defects in materials and workmanship. For a copy of our complete warranty statement, please refer to server-products.com.

Bid Description

Supreme™ butter server features rounded corners and is constructed of brushed (#4) stainless steel body with black thermoset plastic bottom and top. Dispenses directly from a supplied 3 quart (2.8 L) stainless steel jar. Pump features a cast valve body and welded construction. Pump yields 1 ounce (30 ml) with gauging collars supplied to reduce the yield in 1/8 ounce (3.7 ml) increments. Includes magnetic Butter merchandising sign (86791).

An adjustable, precalibrated thermostat controls the heating element. Features a "Power On" light and water fill line.

The BSW-SS is designed with pump and spout warmer opposite the instrument panel side. An On/Off rocker switch controls power to the unit. Has 517 watts.

Standard Features

- NSF-Listed as a rethermalization unit
- Pump design prevents loss of valve balls
- 1 oz (30 mL) maximum portion, now adjustable in 1/8 ounce (3.7 mL) increments — allows for Portion Optimization™
- Adjustable, precalibrated thermostat for accurate heat control
- Temperature marks on knob with protective knob guard
- Water fill line eliminates overflow accidents
- Includes magnetic Butter merchandising sign

Accessory Items

- 3 qt (2.8 L) Stainless Steel Jar 94009
- Stainless Steel Jar, Storage Lid 94008

Specifications on reverse side



Model BSW-SS

FOOD WARMERS {MERCHANDISERS} BUTTER SERVER, SUPREME™

Butter Server Supreme™ with Spout Warmer & Pump

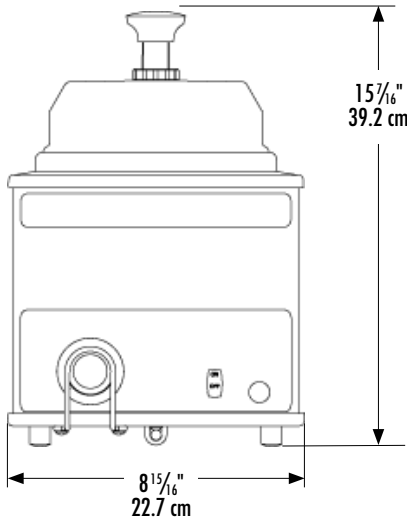

Specifications

Construction	Stainless steel base with black thermoset plastic bottom and top. Pumps feature a rugged cast valve body and welded construction.			
Capacity	Stainless steel jar holds 3 quarts (2.8 L), (not included).			
Dimensions	<u>Height</u>	<u>Width</u>	<u>Depth</u>	<u>Dim.A</u>
	in 15 ⁷ / ₁₆	8 ¹⁵ / ₁₆	15 ¹ / ₂	3 ¹ / ₁₆
	cm 39.2	22.7	39.4	7.8
Electrical	120V, 60Hz, 517W, 4.3A, 72 in (183 cm) cord set NEMA 5-15P, 15A, 125V PLUG			
Weight	16 lb (7.3 kg)			

FOB Richfield, Wisconsin 53076

NSF Listed as a rethermalization unit to ensure food is quickly heated to a safe temperature before bacteria has an opportunity to grow. 

CAD Library

Individual CAD images can be downloaded from our website. We are also a member of The KCL CADalog with more than 100 other manufacturers. Our complete collection of CAD files can be purchased through Kochman Consultants, Ltd. at kclcad.com.

