



FOOD WARMERS {HOT TOPPING} CONE DIP WARMERS

Models DI-1
DI-2, DI-3

Date:

Project:

Quantity:

Item Number:



DI-2 92020



US LISTED

ALSO AVAILABLE FOR EXPORT

Two Year Warranty

Server Products equipment is backed by a two-year limited warranty against defects in materials and workmanship. For our complete warranty statement, please refer to server-products.com.

CAD Library

Individual CAD images can be downloaded from our website. We are also a member of The KCL CADalog with more than 100 other manufacturers. Our complete collection of CAD files can be purchased through Kochman Consultants, Ltd. at klcad.com.

Bid Description

All stainless steel construction with a brushed (#4) finish. Dip servers have a removable bottom and top and feature a hinged lid. Flanges in top extend down into the jar to prevent dripping into warmer. We recommend dipping from our NSF approved stainless steel jar (not included). Your local jurisdiction may not permit dispensing from a #10 can. The hinged lid stays open for dipping.

Adjustable precalibrated thermostat controls a tubular heating element. Heats by natural convection through air. Temperature settings—marked as low or high—range from 50° F (10° C) to 150° F (66° C).

DI-1 capacity is (1) Stainless Steel Jar (94009) or #10 can. The 100 watt heating element is thermostatically controlled.

DI-2 capacity is (2) Stainless Steel Jars (94009) or #10 can. The 120 watt heating element is thermostatically controlled.

DI-3 capacity is (3) Stainless Steel Jars (94009) or #10 cans. The 180 watt heating element is thermostatically controlled.

Standard Features

- All stainless steel construction for durability
- Hinged lid stays open for dipping convenience
- Removable top and bottom for easy cleaning
- Flanges in top prevent dripping into heat zones and hold the can or jar in place
- Adjustable precalibrated thermostat for accurate heat control
- Tubular heating element provides heat through natural convection to eliminate water-bath
- Temperature marks on knob with protective knob guard

Accessory Items

- 3 quart (2.8 L) Stainless Steel Jar 94009
- Storage Lid for Stainless Steel Jar 94008

Specifications on reverse side



FOOD WARMERS {HOT TOPPING} CONE DIP WARMERS

Models DI-1
DI-2, DI-3

Dip Servers

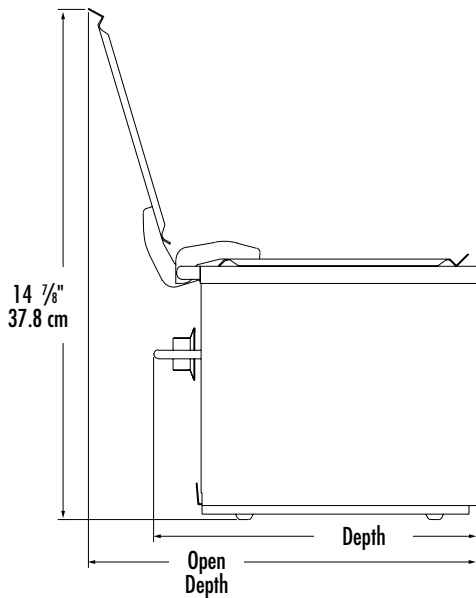
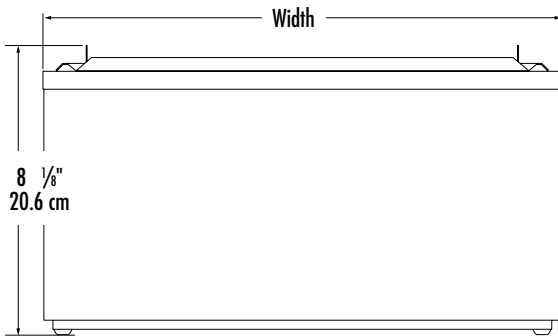

Specifications

Construction | Stainless steel units with a polished finish.
Electrical | 120V, 60Hz

Models	DI-1 92000	DI-2 92020	DI-3 92040
Total Capacity	3 qt 2.8 L	6 qt 5.7 L	9 qt 8.5 L
# of jars or #10 cans	1	2	3
Jar/Can Capacity	3 qt 2.8 L	3 qt 2.8 L	3 qt 2.8 L
Height	8 1/8" 20.6 cm	8 1/8" 20.6 cm	8 1/8" 20.6 cm
Width	7 5/8" 19.4 cm	14 5/8" 37.1 cm	21 5/8" 55 cm
Depth	9 11/16" 24.6 cm	9 7/16" 24 cm	9 7/16" 24 cm
Open Depth	11 9/16" 29.4 cm	11 5/16" 28.7 cm	11 5/16" 28.7 cm
Electrical	100 Watts .8 Amps	120 Watts 1 Amps	180 Watts 1.5 Amps
Weight	7 lb 3.2 kg	9 lb 4.1 kg	12 lb 5.4 kg

FOB Richfield, Wisconsin 53076

