



FOOD WARMERS {MERCHANDISERS} Model FSPW-SS SUPREME™ HOT TOPPER

Date:

Project:

Quantity:

Item Number:



FSPW-SS 81140



US LISTED

ALSO AVAILABLE FOR EXPORT

Bid Description

Supreme™ hot topping server features rounded corners and are constructed of brushed (#4) stainless steel bodies with black thermoset plastic bottom and top. Dispenses directly from a 3 quart (2.8 L) stainless steel jar (not included). The pump features a cast valve body and welded construction and yields 1 ounce (30 mL). Gauging collars are supplied to reduce the yield in 1/8 ounce (3.7 mL) increments.

An adjustable, precalibrated thermostat controls the heating element. Features a "Power On" light and water fill line. Unit includes (3) magnetic merchandising signs: Caramel (86789), Cheese (86787) and Fudge (86788).

Standard Features

- NSF Listed as a rethermalization unit
- Pump design prevents loss of valve balls
- Yields 1 oz (30 mL) maximum portion, adjusts in 1/8 oz (3.7 mL) increments for Portion Optimization™
- Adjustable, precalibrated thermostat for accurate heat control
- Temperature marks on knob with protective knob guard
- Water fill line eliminates overflow accidents
- Includes magnetic signs for versatile merchandising

Accessory Items

- 3 quart (2.8 L) Stainless Steel Jar 94009
- Stainless Steel Jar, Storage Lid 94008

Warranty

Server Products equipment is backed by a two-year limited warranty against defects in materials and workmanship. For a copy of our complete warranty statement, please refer to server-products.com.

Specifications on reverse side



FOOD WARMERS {MERCHANDISERS} Model FSPW-SS SUPREME™ HOT TOPPER

Supreme™ Server with Spout Warmer and Pump

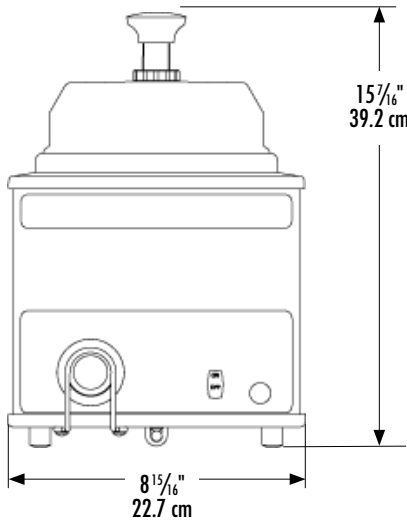

Specifications

Construction	Stainless steel base with black thermoset plastic bottom and top. Pump features a rugged cast valve body and welded construction.			
Capacity	Stainless steel jar or #10 can holds 3 quarts (2.8 L) (not included).			
Dimensions	<u>Height</u>	<u>Width</u>	<u>Depth</u>	<u>Dim.A</u>
	in 15 ⁷ / ₁₆	8 ¹⁵ / ₁₆	15 ¹ / ₂	3 ¹ / ₁₆
	cm 39.2	22.7	39.4	7.8
Electrical	120V, 60Hz, 517W, 4.3A, 72 in (183 cm) cord set NEMA 5-15P, 15A, 125V PLUG			
Weight	15 lb (6.8 kg)			

FOB Richfield, Wisconsin 53076

NSF Listed as a rethermalization unit to ensure food is quickly heated to a safe temperature before bacteria has an opportunity to grow. 

CAD Library

Individual CAD images can be downloaded from our website. We are also a member of The KCL CADalog with more than 100 other manufacturers. Our complete collection of CAD files can be purchased through Kochman Consultants, Ltd. at kclcad.com.

