



# COLD FOOD HOLDERS HOLDCOLD™ JARS

Date:

Project:

Quantity:

Item Number:



**Round HOLDCOLD™ Jars**



**Rectangular HOLDCOLD™ Jars**



## Warranty

Server Products equipment is backed by a two-year limited warranty against defects in materials and workmanship. For our complete warranty statement, see our web site or contact us.

## Bid Description

HOLDCOLD™ Jars are constructed of durable ABS plastic and filled with a non-toxic refrigerant gel. They are available in (2) styles—round or rectangular. Each style can be purchased in black or white or as a kit of (1) black and (1) white jar.

HOLDCOLD™ Jars help hold cream, toppings or condiments below 41° F (5° C) for up to 12 hours, when placed in an insulated unit and filled with refrigerated product. Place jar in the freezer for 8 hours prior to use.

Round jars are used in an insulated unit that accepts a standard #10 can. This includes Server cream servers, cream holders, and insulated condiment server. Round HOLDCOLD™ Jars have a holding capacity of 2¾ quarts (2.6 L).

Each deep fountain jar is notched to allow the lid to close over a ladle for increased sanitation. They also have molded feet to prevent tipping. Rectangular HOLDCOLD™ Jars work in insulated Server units that hold a standard deep fountain jar such as a two, three or four jar serving bar. Holding capacity is 2¼ quarts (2.1 L).

## Standard Features

Double-walled construction assures long-lasting cooling

Eliminates inconvenience and mess of cooling with ice

Holds cream, toppings or condiments cold for up to 12 hours—longer cooling time saves on labor by reducing jar changeovers

Round jars fit in insulated Server units that hold a #10 can

Rectangular jars fit in any Server (2), (3) or (4) jar serving bar—use in place of standard deep fountain jars

Available in black and white or a kit of (1) each

## CAD Library

Individual CAD images can be downloaded from product pages on our web site. We are also a member of The KCL CADalog with more than 100 other manufacturers. Our complete collection of CAD files can be purchased through Kochman Consultants, Ltd. at [kclcad.com](http://kclcad.com).

Specifications on reverse side



# COLD FOOD HOLDERS HOLDCOLD™ JARS

## Round HOLDCOLD™ Jar

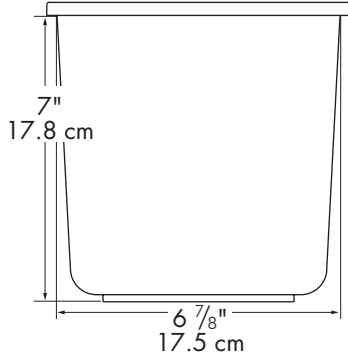

## Rectangular HOLDCOLD™ Jar

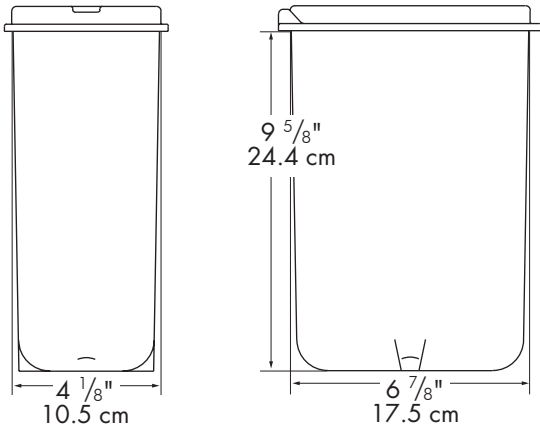

## Specifications

<b>Models</b>	<b>Round HOLDCOLD™ Jars 94055 Black &amp; 94056 White</b>		
Construction	Durable ABS double-walled plastic filled with a non-toxic refrigerant gel.		
Capacity	2 ¾ quarts (2.6 L)		
Dimensions	<u>Height</u>	<u>Depth</u>	
	in 7	6 <sup>7</sup> / <sub>8</sub>	
	cm 17.8	17.5	
Weight	3 lb (1.4 kg)		
Option	Kit (94057) of (1) each (94055) Black & (94056) White Round HOLDCOLD™ Jars. Weight is 6 lb (2.7 kg).		
<b>Models</b>	<b>Rectangular HOLDCOLD™ Jars 82632 Black &amp; 82633 White</b>		
	Same as above except:		
Capacity	2 ¼ quarts (2.1 L)		
Dimensions	<u>Height</u>	<u>Width</u>	<u>Depth</u>
	in 9 <sup>5</sup> / <sub>8</sub>	4 <sup>1</sup> / <sub>8</sub>	6 <sup>7</sup> / <sub>8</sub>
	cm 24.4	10.5	17.5
Weight	4 lb (1.8 kg)		
Option	Kit (82634) of (1) each (82632) Black & (82633) White Rectangular HOLDCOLD™ Jars. Weight is 8 lb (3.6 kg).		

FOB Richfield, Wisconsin 53076



Server Products, Inc. • P.O. Box 98 • Richfield, WI 53076 • Toll Free: 800-558-8722  
P: 262-628-5600 • F: 262-628-5110 • [spsales@server-products.com](mailto:spsales@server-products.com) • [server-products.com](http://server-products.com)

Server Products, Inc. reserves the right to modify specifications without obligation. Printed in USA

10-2008/.5M Stock #02059