



PUMPS {SOLUTION™, PLASTIC} FOOD CONTAINER PUMPS

Models SS1
SS1L

Date:

Project:

Quantity:

Item Number:



SS1 67100



THIN THICK PARTICULATE
See category tab for details.



Warranty

Server Products equipment is backed by a two-year limited warranty against defects in materials and workmanship. For our complete warranty statement, see our web site or contact us.

Bid Description

Constructed of stainless steel with a brushed (#4) finish. The single stand holds a #10 can, Stainless Steel Jar (94009) or 1 gallon (3.8 L) jar. Includes a PSSS-F (83410) Polycarbonate pump.

The Server Solution™ pump dispenses a wide range of products from syrups to relish simply by changing the discharge fitting. Pump parts are dishwasher safe and replaceable. Maximum stroke yields 1 ounce (30 mL) with gauging collars supplied to reduce yield in ¼ ounce (7 mL) increments.

The Single Stand Lockable SS1L (67120) includes a hasp so pump lid can be padlocked to base shroud. Padlock not included.

Standard Features

Durable Polycarbonate pump dispenses a wide range of products from syrups to some relishes

Pump is dishwasher safe for easy clean up

Maximum stroke yields 1 ounce (30 mL)

Easy-to-adjust portion control in ¼ ounce (7 mL) increments

Single Stand Accessories

- Stainless Steel Jar 94009
- Stainless Steel Jar Storage Lid 94008



PUMPS {SOLUTION™, PLASTIC} FOOD CONTAINER PUMPS

Models SS1
SS1L

Single Stand Assembly SS1 67100

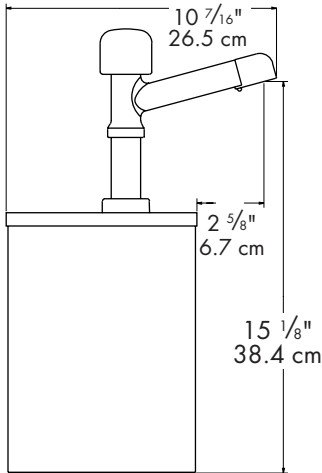
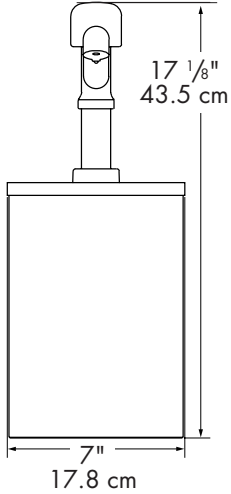

Specifications

Model	SS1 67100		
Construction	Stainless steel base with a brushed (#4) finish. Includes a PSSS-F Polycarbonate pump.		
Capacity	Each end well holds a #10 can, 3 qt (2.8 L) (94009) or 1 gallon (3.8 L) jar.		
Dimensions	<u>Height</u>	<u>Width</u>	<u>Depth</u>
	in	7	10 ⁷ / ₁₆
	cm	17.8	26.5
Weight	7 lb (3.2 kg)		
Model	SS1L 67120		
Construction	Includes hasp so pump can be padlocked (padlock not included).		

FOB Richfield, Wisconsin 53076

CAD Library

Individual CAD images can be downloaded from product pages on our web site. We are also a member of The KCL CADalog with more than 100 other manufacturers. Our complete collection of CAD files can be purchased through Kochman Consultants, Ltd. at kclcad.com.

