



# PUMPS {SOLUTION™, PLASTIC} FOUNTAIN JAR PUMPS

Models PS-F  
PS-200

Date:

Project:

Quantity:

Item Number:



**PS-200 84060**

### WHAT DO YOU DISPENSE?

THIN (syrops)    THICK (ketchup/mayo)    PARTICULATE (tartar sauce)

Server Solution™ style pumps dispense thin and thick condiments with particulates.



### Two Year Warranty

Server Products equipment is backed by a two-year limited warranty against defects in materials and workmanship. For our complete warranty statement, see our website or contact us.

### Bid Description

Server Solution™ pumps are designed to dispense a wide range of products from syrups to some relishes simply by choosing from the (3) discharge fittings (included). The polycarbonate pump parts are dishwasher safe and replaceable. Maximum stroke yields 1 ounce (30 mL) with gauging collars supplied to reduce yield in ¼ ounce (7 mL) increments. A pump and jar drop into a countertop or can be placed into a Syrup Rail or insulated Serving Bar.

The PS-F pumps from a standard 10" (25.4 cm) fountain jar. PS-200 pumps from a 7½" (19 cm) fountain jar.

### Standard Features

- Durable polycarbonate construction
- Dishwasher safe for easy clean up
- Pump a wide range of products from syrups to relish
- Maximum stroke yields 1 ounce (30 mL)
- Easy-to-adjust portion control in ¼ ounce (7 mL) increments
- (3) discharge fittings to accommodate various products

### Accessory Items

- Fountain Jar, deep—Stainless Steel 82555
- Fountain Jar, deep—Polypropylene 82557
- Fountain Jar, shallow—Stainless Steel 82556
- Fountain Jar, shallow—Polypropylene 82558



# PUMPS {SOLUTION™, PLASTIC} FOUNTAIN JAR PUMPS

Models PS-F  
PS-200

## Fountain Jars—PS-F and PS-200

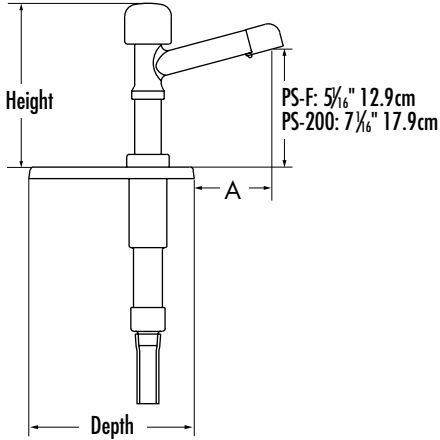

## Specifications

<b>Model</b>	<b>PS-F 81910</b>				
Construction	Durable Polycarbonate, pump parts. Stainless steel lid fits a deep fountain jar (sold separately).				
Capacity	Standard deep fountain jar has a 3½ quart (3.3 l) capacity.				
Dimensions (above jar)		<u>Height</u>	<u>Width</u>	<u>Depth</u>	<u>Dim. A</u>
	in	7 1/8	4 1/2	7 1/8	3 3/8
	cm	18.1	11.4	18.1	8.6
Weight	2 lb (.9 kg)				
Cutout Size	4 5/16 x 7 in (11 x 17.8 cm)				
<b>Model</b>	<b>PS-200 84060</b>				
	Same as above except:				
Construction	Fits a shallow fountain jar.				
Capacity	2 quart (1.9 l) capacity				
Dimensions (above jar)		<u>Height</u>	<u>Width</u>	<u>Depth</u>	<u>Dim. A</u>
	in	9 1/8	4 1/2	7 1/8	3 3/8
	cm	23.2	11.4	18.1	8.6

FOB Richfield, Wisconsin 53076

## CAD Library

Individual CAD images can be downloaded from our website. We are also a member of The KCL CADalog with more than 100 other manufacturers. Our complete collection of CAD files can be purchased through Kochman Consultants, Ltd. at [kclcad.com](http://kclcad.com).

