



TOPPING STATIONS DRY PRODUCT DISPENSERS

Model DPD

Date:

Project:

Quantity:

Item Number:



DPD 1-Liter Single 86670 (left)
DPD 2-Liter Single 86680 (right)



Two Year Warranty

Server Products equipment is backed by a two-year limited warranty against defects in materials and workmanship. For our complete warranty statement, please refer to server-products.com.

Bid Description

The Dry Product Dispenser is a hopper system that accurately portions powders and other dry products. The dispenser allows portions from ¼ to 2 ounces (7 to 60 ml) by volume and is adjustable in ⅛ ounce (3.4 ml) increments. Suggestions for use include smoothie powders, iced coffee powders, mix-ins for blended ice cream drinks and cocktail powders.

Dry Product Dispensers are designed to be mounted side by side for a station of several products. Choose from 1 or 2 liter capacity models with a single, double or triple wall bracket. A double stand is available, to convert your double 1 or 2 liter model for countertop use.

A guideline for product use would be as long as it is consistent and not much bigger than ½ inch (1.3 cm) in diameter. Dissimilar products and those that tend to melt or stick together at room temperature such as crushed candy bars are not recommended. Very fine protein or malt powders may bridge as the hopper empties. The addition of our Free Flow Accessory should solve bridging while the Stir Paddle Accessory addresses irregular pieces such as cookie crumbles.

Standard Features

- Durable, clear polycarbonate hopper shows off product
- Accurately dispense dry products of a consistent material
- Dispense between ¼ and 2 oz (7 and 60 ml) by volume
- Adjust portions in ⅛ oz (3.4 ml) increments
- No need to worry about accidental portion changes; disassembly is necessary for portion adjustment
- Takes up just (5) linear inches (12.7 cm) of wall space and includes handy wall mount bracket

Accessory Items

- Double Stand 86561
(for use with Double 86640 or 86690 models)
- Free Flow Accessory, 1-Liter 86663, 2-Liter 86625
- Stir Paddle Accessory, 1-Liter 86587, 2-Liter 86596
- 5" (12.7 cm) deep Extention Shelf 86754 for Double models and 86755 for Triple models

Specifications on reverse side



TOPPING STATIONS DRY PRODUCT DISPENSERS

Model DPD

Dry Food Dispensers

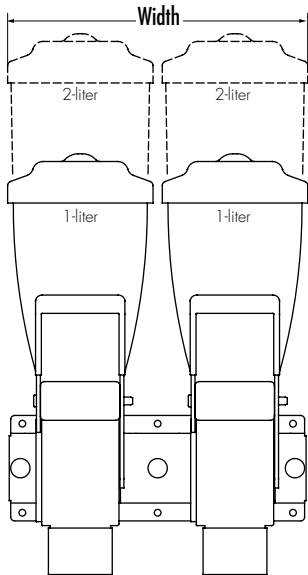
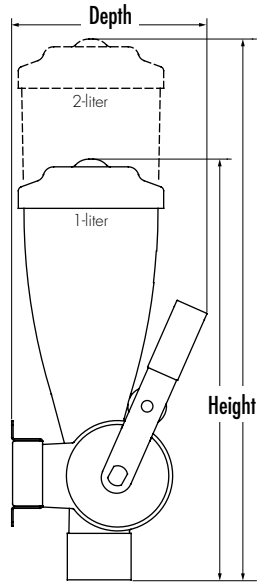

Specifications

Models	Single 86670	Double 86690	Triple 86650
Height	13 ⁹ / ₁₆ " 34.5 cm	13 ⁹ / ₁₆ " 34.5 cm	13 ⁹ / ₁₆ " 34.5 cm
Width	4 ¹¹ / ₁₆ " 11.9 cm	9 ¹¹ / ₁₆ " 24.6 cm	14 ¹¹ / ₁₆ " 37.3 cm
Depth	6 ⁵ / ₁₆ " 16 cm	6 ⁵ / ₁₆ " 16 cm	6 ⁵ / ₁₆ " 16 cm
Capacity	1 Liter	1 Liter	1 Liter
Weight	5 lb 2.3 kg	9 lb 4.1 kg	11 lb 5 kg
Models	Single 86680	Double 86640	Triple 86660
Height	17 ⁷ / ₁₆ " 44.3 cm	17 ⁷ / ₁₆ " 44.3 cm	17 ⁷ / ₁₆ " 44.3 cm
Width	4 ¹¹ / ₁₆ " 11.9 cm	9 ¹¹ / ₁₆ " 24.6 cm	14 ¹¹ / ₁₆ " 37.3 cm
Depth	6 ⁵ / ₁₆ " 16 cm	6 ⁵ / ₁₆ " 16 cm	6 ⁵ / ₁₆ " 16 cm
Capacity	2 Liter	2 Liter	2 Liter
Weight	5 lb 2.3 kg	9 lb 4.1 kg	12 lb 5.4 kg

FOB Richfield, Wisconsin 53076

CAD Library

Individual CAD images can be downloaded from our website. We are also a member of The KCL CADalog with more than 100 other manufacturers. Our complete collection of CAD files are available on the product detail page of our website or can be purchased through Kochman Consultants, Ltd. at kclcad.com.

