



TOPPING STATIONS {WHIPPED SOLUTIONS} RICH'S® TOPPING TUNNEL™

Model TT

Date:

Project:

Quantity:

Item Number:



TT 86624



Patent Pending

Two Year Warranty

Server Products equipment is backed by a two-year limited warranty against defects in materials and workmanship. For our complete warranty statement, please refer to server-products.com.

Bid Description

Server Products, together with Rich Products Corporation, a leader in whipped topping, have collaborated to bring you convenient dispensing options which meet your operational needs.

The Topping Tunnel™ is a handy holder and dispenser for specified Rich's® Whipped Topping products (see back for list). Each Topping Tunnel™ is NSF listed and readily adapts to a wide variety of foodservice equipment. Simply place the Rich's® pastry bag into the dispensing unit (tip down), give a gentle squeeze and you're ready to dollop a wide variety of food items quickly and safely. When you're done dolloping, the Topping Tunnel™ quickly detaches from the bracket for cleaning.

Standard Features

- Accommodates specified Rich's® Whipped Topping Patent pending design permits single-handed dispensing
- Achieves superior evacuation of the pastry bag
- Topping Tunnel™ removes easily from mounting bracket for quick clean-up
- Mounting bracket is secured with heavy duty suction cups for effortless installation and removal when cleaning
- Dishwasher safe

Studies Show

Operators that offered cold and frozen beverages with Whipped Topping grew servings over 79% the past five years!

Source: NPD Food World CREST — 52 Weeks ending July 2006

Operators that offered hot beverages with Whipped Topping grew servings over 52% in the past five years!

Source: NPD Food World CREST — 52 Weeks ending July 2006

Rich's® On Top® Whipped Topping significantly outperformed all other topping alternatives in overall consumer liking scores for visual appearance!

Source: Rich's® Proprietary Research 2007

When garnished with 1-oz (7 mL) of Rich's® On Top® Whipped Topping; consumers were willing to pay an average of \$1.10 more for a milkshake and \$1.50 more for a hot chocolate!

Source: Ignite Communications 2006

Specifications on reverse side



Model TT

TOPPING STATIONS {WHIPPED SOLUTIONS} RICH'S® TOPPING TUNNEL™

Topping Tunnel™ TT 86624

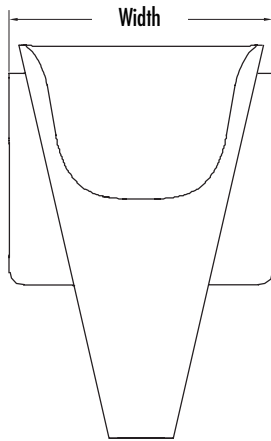
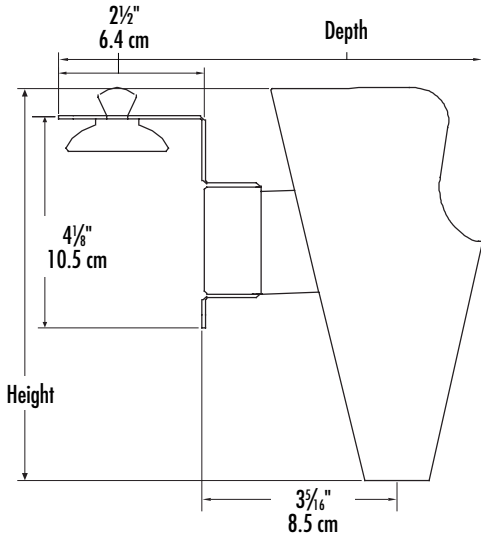

Specifications

Model	TT 86624		
Construction	Stainless steel mounting bracket, ABS/Poly blend Topping Tunnel™ & rubber suction cups.		
Capacity	Up to 16 oz (454 g) Rich's® Whipped Topping		
Dimensions	<u>Height</u>	<u>Width</u>	<u>Depth</u>
	in 7 ⁵ / ₈	4 ¹ / ₂	7 ¹ / ₄
	cm 19.4	11.4	18.4
Weight	2 lb (.9 kg)		

RICH'S Pre-Whipped Topping Products

Contact your Rich's® representative, to purchase Whipped Topping products for the Topping Tunnel™. Now with Rich's® patent pending D-Disc™, for easier handling.

NOTE: Be sure to refrigerate your Rich's® On Top® when not in use.

PC#62567	On Top® Vanilla	(15) 8 oz (227G)
PC#02559	On Top® Vanilla	(12) 16 oz (454G)
PC#01855	On Top® Chocolate	(10) 16 oz (454G)
PC#02090	Sugar-Free On Top® Vanilla	(12) 16 oz (454G)

Topping Tunnel is a trademark owned by Rich Products Corporation.
FOB Richfield, Wisconsin 53076

CAD Library

Individual CAD images can be downloaded from our website. We are also a member of The KCL CADalog with more than 100 other manufacturers. Our complete collection of CAD files can be purchased through Kochman Consultants, Ltd. at kclcad.com.

