



TOPPING STATIONS {WHIPPED TOPPING SOLUTIONS} TOPPING TRIGGER™

Model TOPT

Date:

Project:

Quantity:

Item Number:



TOPT 87060



TOPT 87079

Bid Description

Server Products, together with Rich Products Corporation, the leader in whipped topping, have collaborated to bring you convenient dispensing options which meet your operational needs.

The Topping Trigger™ is a hand held dispenser that delivers a controlled dollop of specified Rich's® Whipped Topping. Compatible packaging is a **NEW** patent pending cylindrical design. See back for listing. Each squeeze of the trigger dispenses a full dollop with three settings to reduce dollop portion. The system is NSF listed and designed with safety in mind, no compressed gas required.

Standard Features

- Accommodates new specified Rich's® Whipped Topping
- Sealed system virtually eliminates cross contamination risk
- Design permits single-handed dispensing
- Flexible product package maximizes evacuation
- Portion options: (1) Full & (3) reduced portions
- Recyclable packaging eliminates solid waste issues & nitrous oxide (N₂O) concerns
- Free standing & portable — easily fits into any operation
- Dishwasher safe for fast & easy clean-up

Two Year Warranty

Server Products equipment is backed by a two-year limited warranty against defects in materials and workmanship. For our complete warranty statement, please refer to server-products.com.



Patent Pending



Model TOPT

TOPPING STATIONS {WHIPPED TOPPING SOLUTIONS}
TOPPING TRIGGER™

Topping Trigger™

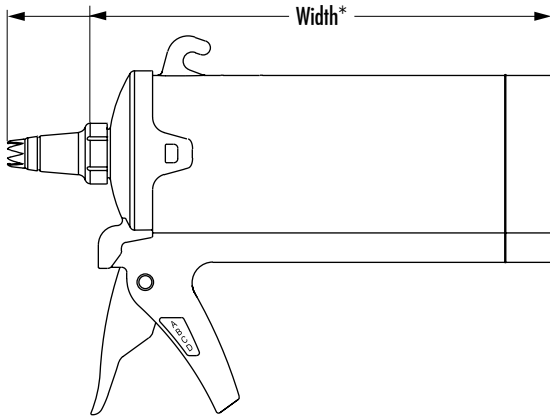

Specifications

Model	TOPT 87060 & 87079-OT			
Construction	Durable ABS/Polycarbonate blend with stainless steel drive mechanism.			
Capacity	Up to 11.5 oz (326 g) Rich's® Whipped Topping			
Dimensions	<u>Height</u>	<u>Width</u>	<u>Width*</u>	<u>Depth</u>
	in 9 1/16	13 1/16	11 7/8	4
	cm 23	33.2	30.2	10.4
	Width* is without extender tip installed.			
Weight	3 lb (1.4 kg)			

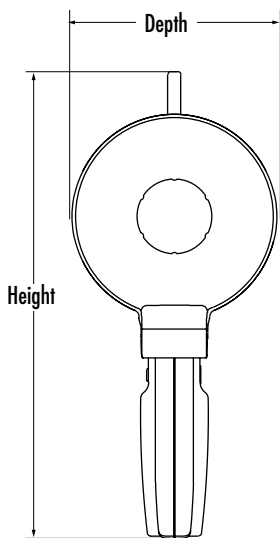

RICH'S® Pre-Whipped Topping Product

Contact your Rich's® representative, to purchase Whipped Topping product for the Rich's® Whipped Topping Dispensing System™.

NOTE: This is a NEW cylindrical bag design.

PC 05543 On Top® Whipped Topping (16) 11.5 oz (326 g)

Be sure to refrigerate your Rich's® On Top® Whipped Topping, when not in use.

Topping Trigger™ is a trademark owned by Rich Products Corporation. Rich's® and On Top® are registered trademarks of Rich Products Corporation.

FOB Richfield, Wisconsin 53076

CAD Library

Individual CAD images can be downloaded from our website. We are also a member of The KCL CADalog with more than 100 other manufacturers. Our complete collection of CAD files can be purchased through Kochman Consultants, Ltd. at kclcad.com.

